

PROPRIETARY AND CONFIDENTIAL

THE INFORMATION CONTAINED IN THIS DRAWING IS THE SOLE PROPERTY OF DYTRAN INSTRUMENTS INC. ANY REPRODUCTION IN PART OR AS A WHOLE WITHOUT THE WRITTEN PERMISSION OF DYTRAN INSTRUMENTS INC. IS PROHIBITED

MODEL	INPUT RANGE
7613A1-XX	±2g
7613A2-XX	±5g
7613A3-XX	±10g
7613A4-XX	±25g
7613A5-XX	±50g
7613A6-XX	±100g
7613A7-XX	±200g
7613A8-XX	±400g

REVISIONS

REV.	ECN	DESCRIPTION	BY/DATE	CHK	APPR
A	14343	INITIAL RELEASE. SAME AS REV X4.	KG 07/12/18	W	AS

1 CABLE LENGTH TOLERANCE

ENGLISH		[METRIC]	
≤1FT	+1/ -0 IN	≤0.3m	+25mm -0mm
>1 FT - 5 FT	+2/ -0 IN	.0.3 m-1.5m	+50mm -0mm
> 5 FT - 10 FT	+4/ -0 IN	>1.5m-3m	+100mm -0mm
>10 FT - 25FT	+6 / -0 IN	>3m-7.5m	+150mm -0mm
>25 FT	+5% / -0%	>7.5m	+5%/-0%

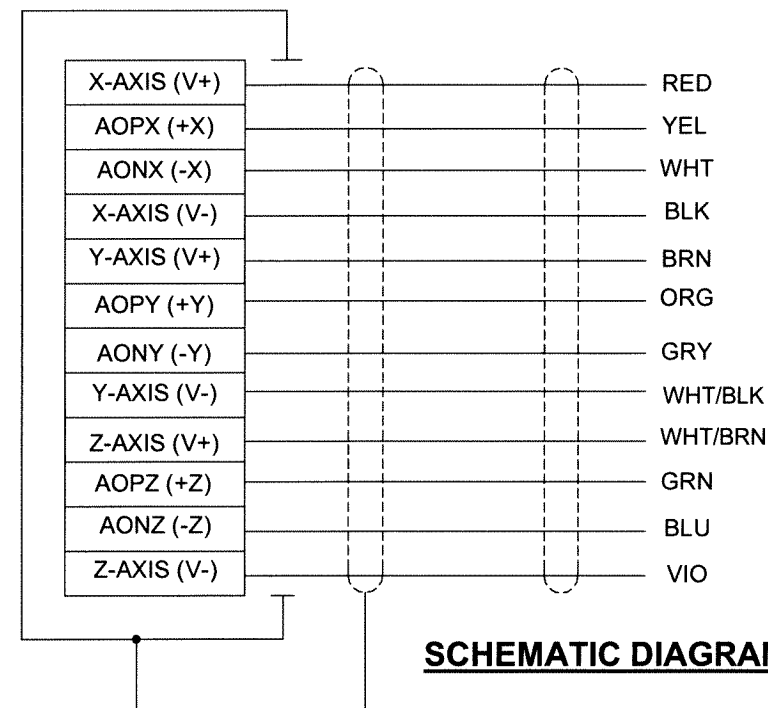
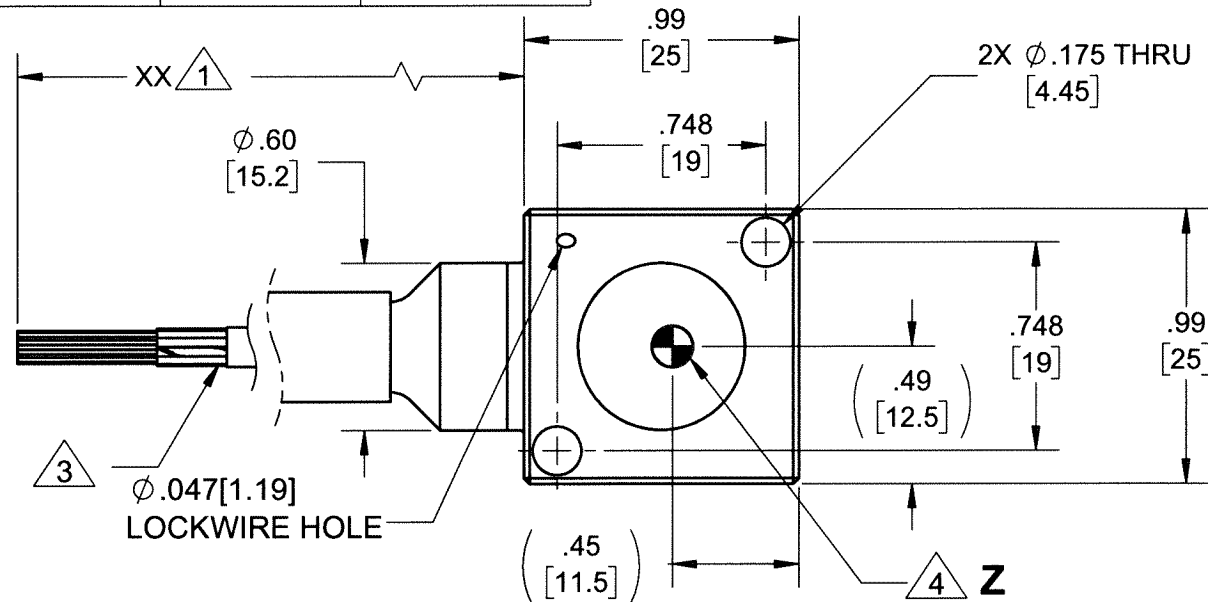

SCHEMATIC DIAGRAM

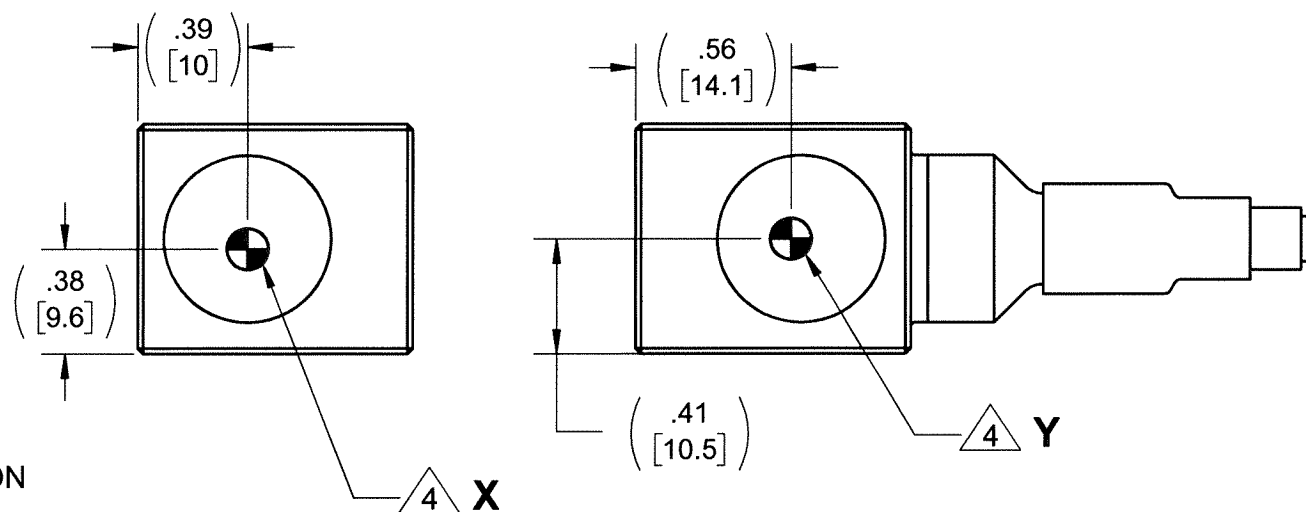
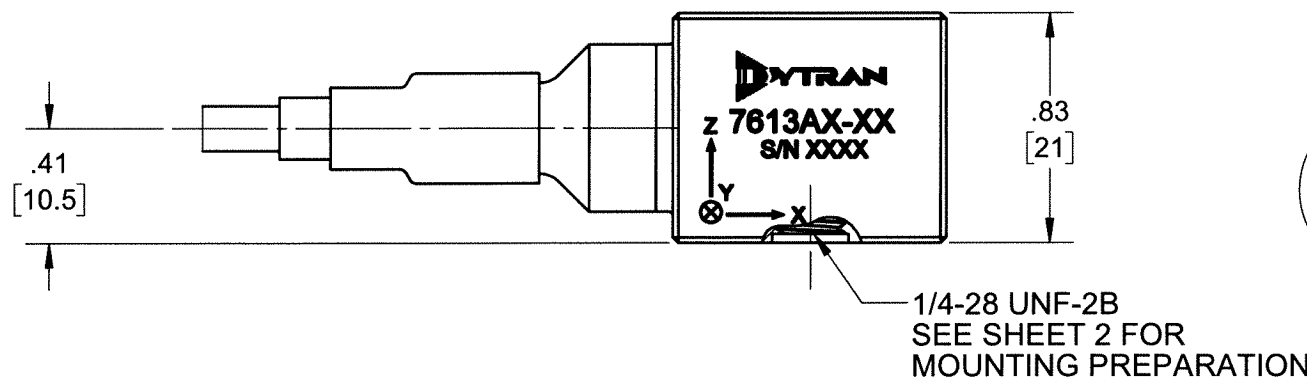

5. MINOR VOIDS, SCARS, SCRATCHES AND MOUNTING BLEMISH/WITNESS MARKS ON EXTERIOR SURFACES ARE ALLOWED DUE TO RESTRAINING AND HANDLING DURING TESTING, TRANSPORT OR PROCESSING. THESE APPEAR AS INDICATORS THAT DO NOT AFFECT FORM, FIT OR FUNCTION AS INTENDED BY DESIGN OR APPLICATION

4 MARKING DENOTES LOCATION OF SENSING ELEMENT'S CENTER OF MASS

3 SEE SHEET 2 TABLE FOR CABLE SPECIFICATIONS.

2. MATERIAL: TITANIUM ALLOY. WEIGHT: 45 GRAMS MAX, LESS CABLE.

1 PART NUMBER 7613AX-XX. "XX" DENOTES LENGTH IN FEET. SEE TABLE FOR LENGTH TOLERANCE

NOTES: UNLESS OTHERWISE SPECIFIED

UNLESS OTHERWISE SPECIFIED: INTERPRET DIM & TOL PER ASME Y14.5M - 1994. REMOVE BURRS. COUNTERSINK INTERNAL THDS 90° TO MAJOR DIA. CHAM EXT THDS 45° TO MINOR DIA. THD LENGTHS AND DEPTHS ARE FOR MIN FULL THDS. DIMENSIONS APPLY AFTER FINISHING.

ALL MACHINED SURFACES. TOTAL RUNOUT WITHIN .005. BREAK SHARP EDGES .005 TO .010. MACHINED FILLET RADII .005 TO .015. WELDING SYMBOLS PER AWS A2.4. ABBREVIATIONS PER MIL-STD-12.

UNLESS OTHERWISE SPECIFIED: DIMENSIONS ARE IN INCHES. DIMENSIONS IN BRACKETS [] ARE IN MILLIMETERS TOLERANCES ARE: DECIMALS .XX ±.03 .XXX ±.010 METRIC .X ±0.8 .XX ±0.25 ANGLES ±1°

APPROVALS		DATE
ORIG	LN	09/13/17
CHK	W	8/1/18
APP	AS	8/14/19

DYTRAN INSTRUMENTS, INC. CHATSWORTH, CA

MASTER COPY ONLY IN RED

TITLE: **OUTLINE/INSTALLATION DWG, TRIAXIAL DC ACCELEROMETER, 7613AX-XX SERIES**

SIZE B	CAGE CODE 2W033	DWG NO 127-7613AX-XX	REV A
---------------	------------------------	-----------------------------	--------------

DO NOT SCALE DRAWING

SCALE: 3:2

SHEET 1 OF 2

PROPRIETARY AND CONFIDENTIAL

THE INFORMATION CONTAINED IN THIS DRAWING IS THE SOLE PROPERTY OF DYTRAN INSTRUMENTS INC. ANY REPRODUCTION IN PART OR AS A WHOLE WITHOUT THE WRITTEN PERMISSION OF DYTRAN INSTRUMENTS INC. IS PROHIBITED

3 12 CONDUCTOR CABLE

WIRE TYPE	EXTRUDED FEP INSULATION .006 WALL THICKNESS
TEMPERATURE	200°C
VOLTAGE	600 VOLTS
WIRE DIAMETER	.032 NOMINAL
SHIELD	38 AWG SILVER PLATED COPPER BRAIDED 95% COVERAGE 7E-16C36F/30B
JACKET	EXTRUDED WHITE FEP .010 WALL THICKNESS
CABLE DIA.	Ø .171, NOM
12 CONDUCTOR AWG	26-7/34 SILVER PLATED COPPER

2X FLAT WASHERS, MODEL 6754, SUPPLIED

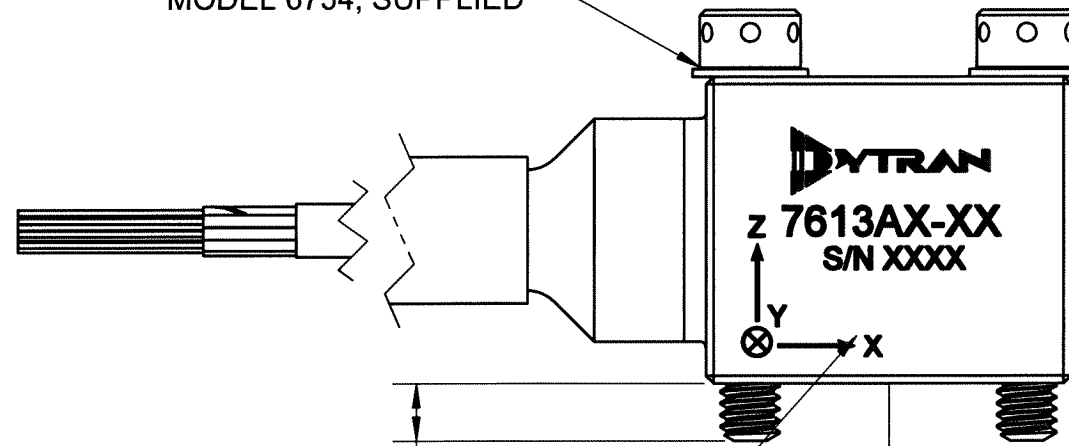

2X MOUNTING SCREW, MODEL 69034A16 (8-32 x 1.0), SUPPLIED
2X MOUNTING SCREW, MODEL 6687A1 (M4x0.7 X 25mm), SUPPLIED

RECOMMENDED MOUNTING PREPARATION:
PREPARE FLAT MOUNTING SURFACE EQUAL TO OR BETTER THAN .001 TIR. TAP 8-32 UNRC-3B .200 MIN. (OR 2X M4 X 0.7-6g .20 [5.1] MIN.)
RECOMMENDED TORQUE 10-12 LB-IN. (1.12-1.35 N-m).

(2X .16 [3.9])

1/4-28 UNF-2B

(1/4-28 UNF-2A)

(M6 X 1)

MOUNTING STUD, MODEL 6360, 1/4-28 TO 1/4-28, SUPPLIED

STUD, MODEL 6691, 1/4-28 UNF-2A TO M6 X 1, SUPPLIED

RECOMMENDED MOUNTING PREPARATION: MODEL 6360
PREPARE MOUNTING SURFACE, Ø 1.25 [31.2] MIN, FLAT TO .001 TIR.
TAP 1/4-28 UNF-2B ∇ .200 [5.1] MIN. TORQUE TO 12-15 Lb-in.

RECOMMENDED MOUNTING PREPARATION: MODEL 6691
PREPARE MOUNTING SURFACE, Ø 1.25 [31.2] MIN, FLAT TO .001 TIR.
TAP M6 X 1 ∇ .200 [5.1] MIN. TORQUE TO 12-15 Lb-in.

DYTRAN INSTRUMENTS, INC. MASTER COPY IN RED
Chatsworth, CA

TITLE: **OUTLINE/INSTALLATION DWG, TRIAXIAL DC ACCELEROMETER, 7613AX-XX SERIES**

SIZE B	CAGE CODE 2W033	DWG NO 127-7613AX-XX	REV A
---------------	------------------------	-----------------------------	--------------

SCALE: 2:1 SHEET 2 OF 2

Model Number 7613A1-XX	PERFORMANCE SPECIFICATION	DOC NO PS7613A1-XX
TRIAxIAL VARIABLE CAPACITANCE ACCELEROMETER		REV B, ECN 14672, 11/30/18



- VARIABLE CAPACITANCE TECHNOLOGY
- DIFFERENTIAL MODE
- HERMETICALLY SEALED
- DC RESPONSE

This family also includes:

Model	Input Range (g)	Frequency Response (Hz) +/-3dB	Sensitivity Differential, ±5% (mV/g)	Max.Shock (0.1ms)	Noise Differential (µg/√Hz)
7613A2-XX	±5	0-500	100	2000	12
7613A3-XX	±10	0-1000	50	5000	18
7613A4-XX	±25	0-1400	20	5000	25
7613A5-XX	±50	0-2000	10	5000	50
7613A6-XX	±100	0-2500	5	5000	100
7613A7-XX	±200	0-3000	2.5	5000	200
7613A8-XX	±400	0-4000	1.25	5000	400

Refer to the performance specifications of the products in this family for detailed description.

Supplied Accessories:

- 1) Accredited calibration certificate (ISO 17025)
- 2) Mounting stud, Model 6360, 1/4-28 UNF-2A, Qty 1
- 3) Mounting stud, Model 6691, 1/4-28 UNF-2A to M6 X 1, Qty 1
- 4) Mounting screws, Model 69034A16, 8-32 x 1.0, Qty. 2
- 5) Mounting screws, Model 6687A1, M4x0.7 x 25mm, Qty. 2
- 6) Flat washers, Model 6754, Qty. 2

Notes:

- [1] 12-conductor, 26AWG, White FEP Jacket
- [2] Single ended sensitivity is half of values shown. (Ref. at 100 Hz)
- [3] -90% to +90% of Full Scale.
- [4] Over the rated temperature range.
- [5] In the interest of constant product improvement, we reserve the right to change specifications without notice.

	ENGLISH		SI	
PHYSICAL				
Weight, Max (Less Cable)	1.6	oz	45	grams
Integral Cable [1]	Flying leads		Flying leads	
Material	Titanium Alloy		Titanium Alloy	
Sensing Technology	MEMS		MEMS	
PERFORMANCE				
Input Range	±2	g	±19.6	m/s ²
Frequency Response	0-200	Hz	0-200	Hz
	0-400	Hz	0-400	Hz
Resonant Frequency	>3000	Hz	>3000	Hz
Sensitivity Differential, ±5% [2]	250	mV/g	25	mV/m/s ²
Output Noise, Differential, Typ	7	µg rms/√ Hz	69	µm/s ² /√ Hz
Non-Linearity, Max [3]	0.5	% F.S	0.5	% F.S
Cross Axis Sensitivity, Max	3	%	3	%
ENVIRONMENTAL				
Maximum Mechanical Shock (0.1 ms)	±2000	gpk	±19620	m/s ² peak
Bias Temperature Shift ,Max [4]	111	(ppm of span)*F	200	(ppm of span)*C
Bias Calibration Error, Max	4	% of span	4	% of span
Operating Temperature Range	-67 to +257	*F	-55 to +125	*C
Seal	Hermetic		Hermetic	
ELECTRICAL				
Output Common Mode Voltage, Typ	2.5	VDC	2.5	VDC
Output Impedance, Nom	1225	Ω	1225	Ω
Operating Voltage	±3 to ±11	VDC	±3 to ±11	VDC
Operating Current, Max. (Each Axis)	13	mA DC	13	mA DC
Power Supply Rejection Ratio	>65	dB	>65	dB

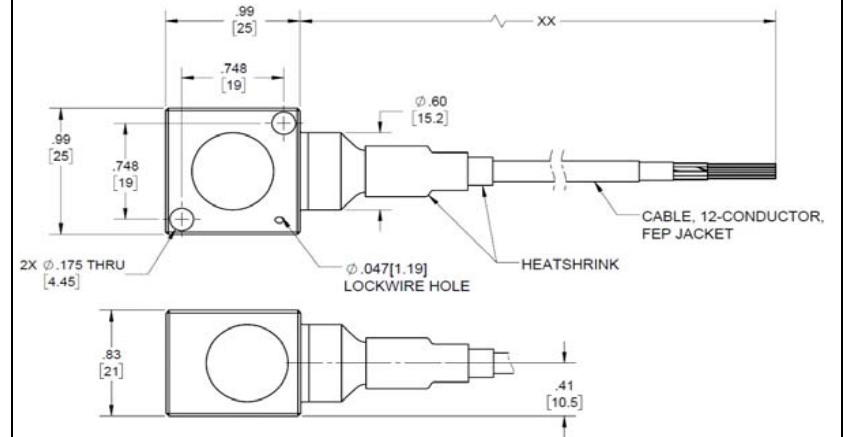

Units on the line drawing are in inches. Refer to 127-7613AX-XX for more information.

