

ThermoView® TV40

Thermal Imager Datasheet

Highlights

- Wide temperature range:
-10 to 1200 °C (14 to 2192 °F)
- 320 x240 and 640 x 480 infrared resolution
- 9 or 60 Hz models available
- Rugged housing, IP67 (NEMA 4) rated
- Sighting: IR-Fusion® technology (thermal and visible sighting) for easy alignment and added detail on blended images
- Remote motorized focus
- Multiple field interchangeable lens options available
- GigE Vision interface
- LAN/Ethernet with PoE for communication with the thermal imager provides access to Ethernet, Web server and ThermoView Software
- ThermoView software for industrial automation applications
- Ambient temperatures to 200 °C (392 °F) with high temperature enclosure
- Air purge and accessories available

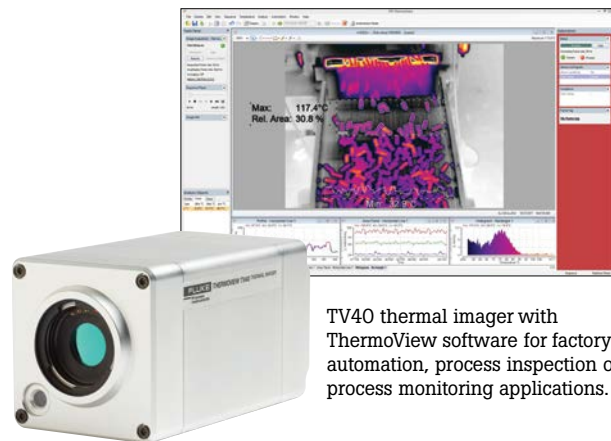

TV40 thermal imager with ThermoView software for factory automation, process inspection or process monitoring applications.

New to the world – a high performance industrial thermal imager from the brand you trust, backed by 150 years of industrial application experience. Designed for the most challenging environmental conditions you face, and supported by an intuitive and powerful analysis software, ThermoView TV40 provides the performance and personalization to meet your process monitoring and control needs.

Lens Field of View examples

Lens Type	Distance		HFOV		VFOV		Pixel Size	
	m	ft.	m	ft.	m	ft.	mm	in.
Standard Lens	0.5	1.6	0.3	1.0	0.2	0.8	0.93	0.037
	1.0	3.3	0.6	2.0	0.5	1.5	1.85	0.073
	3.0	9.8	1.8	6.0	1.4	4.5	5.56	0.219
	10.0	32.8	6.1	20.1	4.6	15.1	18.54	0.730
Wide Angle FPI 0.75X WIDE LENS	0.5	1.6	0.4	1.4	0.3	1.0	1.23	0.048
	1.0	3.3	0.8	2.7	0.6	2.0	2.45	0.097
	3.0	9.8	2.5	8.2	1.8	6.0	7.36	0.290
	10.0	32.8	8.3	27.2	6.1	20.1	24.54	0.966

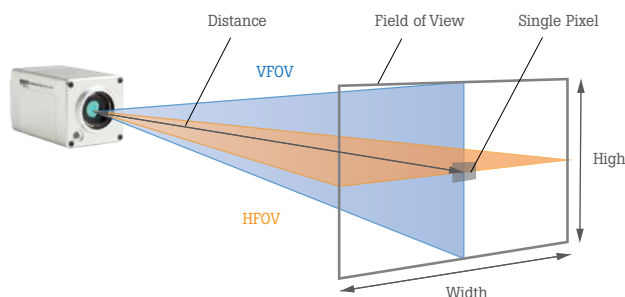

HFOV – Horizontal Field of View (horizontal aperture angle)
VFOV – Vertical Field of View (vertical aperture angle)

Measuring field sizes can be calculated online at:
www.flukeprocessinstruments.com/TV40

Measurement Specifications

	ThermoView TV43	ThermoView TV46
Sighting	Thermal Imager + Visible Light Camera (640 x 480)	
Measuring Range	-10 to 1200 °C (14 to 2192 °F)	
Measurement Accuracy	±2 °C or ±2 % (reading)	
Infrared Resolution	320 x 240 (76,800 pixels)	640 x 480 (307,200 pixels)
Spectral Range	8 - 14 μm	
Detector	Uncooled focal plane array	
Field of View	Horizontal 34° x 25.5°	
Add on Lens Options (add in field)	0.75x Wide lens (45° x 34°) 2x lens (17° x 12.7°) 4x lens (8.5° x 6°) Macro lens	
Focus Range	IR 15 cm – ∞ (motorized remote focus) Visible light: 60 cm – ∞	
Thermal Imager Frame Time	9 or 60 frames/sec. (must be specified at the time of ordering)	
Emissivity Correction	0.10 to 1.00	
Interface	GigE Vision	
LED Display	Power supply indication, system error codes	
Operating Temperature	-10 to 50 °C (14 to 122 °F)	
Storage Temperature	-20 to 50 °C (-4 to 122 °F)	
Humidity	10 – 95 % non-condensing	
Power Supply	DC + 12 to 26 V , PoE (Power over Ethernet)	
Power Consumption	8 W (typical) 13 W (maximum)	
Shock Resistance	IEC 60068-2-27 (mechanical shock): 50 g, 6 ms, 3 axis	
Vibration Resistance	IEC 60068-2-26 (sinusoidal vibration): 3 g, 11 – 200 Hz, 3 axis	
Environmental Protection	IP67 (NEMA 4)	
Dimensions (W x H x L)	Approximately 83 x 83 x 158 mm (3.25 x 3.25 x 6.22")	
Weight	Approximately 1.08 kg (2.38 lbs)	

Thermal Imager rear view



Thermal Imager front view

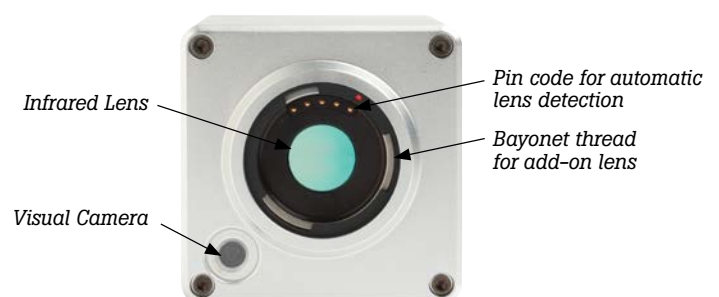

Thermal Imager Dimensions

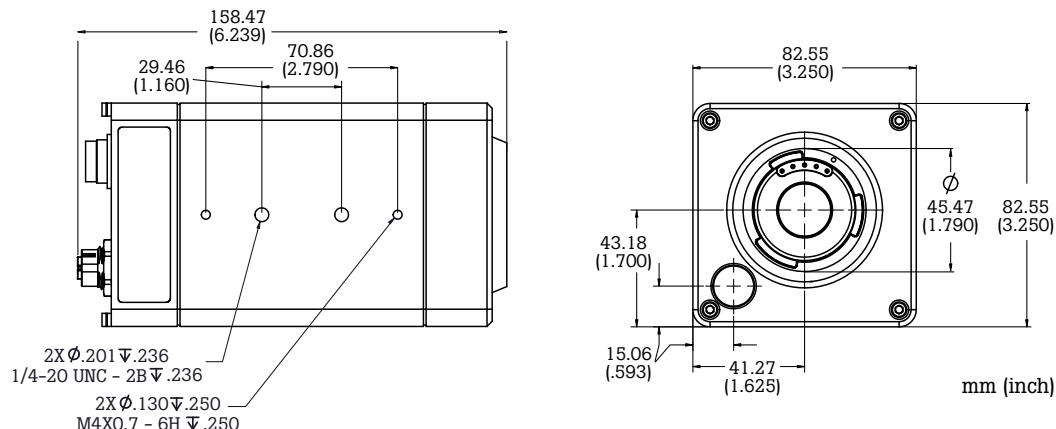

Accessories

TV40 thermal imagers are shipped with manual, calibration certification, quick reference guide, safety sheet.

Additional accessories include but are not limited to:

- Wide Angle for TV43/TV46 (45° x 34°) **(FPI 0.75X WIDE LENS)**
- 2x telephoto for TV43/TV46 (17° x 12.7°) **(FPI 2X LENS)**
- 4x telephoto for TV43/TV46 (8.5° x 6°) **(FPI 4X LENS)**
- Macro Lens for TV43/TV46 **(FPI MACRO LENS)**
- PoE Injector (industrial duty) provides power and also acts as a single Ethernet hub (110/220 VAC input) **(A-TV-POE-2)**
- Air purge collar (includes protective window) **(A-TV-AP)**
- Protective enclosure (water cooled/air purged) **(A-TV-WC)**
- Protective Window - ThermoView **(A-TV-PW)**
- 24 VDC 1.2 A industrial power supply, DIN rail mount **(A-PS-DIN-24V)**
- Mounting Base **(A-TV-MB)**

The Fluke Process Instruments Guarantee

The ThermoView TV40 thermal imager is supported by a 2 year warranty. With a network of trained representatives and agents in over one hundred countries and offices located in the U.S., Germany and China, we provide local service and support.

Fluke Process Instruments

Americas

Everett, WA USA
Tel: +1 800 227 8074 (USA and Canada, only)
+1 425 446 6300
solutions@flukeprocessinstruments.com

EMEA

Berlin, Germany
Tel: +49 30 4 78 00 80
info@flukeprocessinstruments.de

China

Beijing, China
Tel: +8610 6438 4691
info@flukeprocessinstruments.cn

Japan

Tokyo, Japan
Tel: +81 03 6714 3114
info@flukeprocessinstruments.jp

Asia East and South

India Tel: +91 22 62495028
Singapore Tel: +65 6799 5578
sales.asia@flukeprocessinstruments.com

Worldwide Service

Fluke Process Instruments offers services, including repair and calibration. For more information, contact your local office.

www.flukeprocessinstruments.com

© 2019 Fluke Process Instruments
Specifications subject to change without notice.
6/2019 6010793A1