

Thunder Scientific Corporation



Humidity Generation,
Calibration and Measurement



Model 2500

*Benchtop / Mobile "Two-Pressure"
Humidity Generator*

Model 2500 Benchtop / Mobile "Two-Pressure" Humidity Generator

FEATURES

- Accuracy ± 0.5 %RH
- Traceable to NIST
- Self Contained and Mobile
- Automated Control of User Setpoints
- ControLog™ Automation Software
- HumiCalc® Humidity Conversion Software
- Computerized Internal Transducer Calibration
- Low Noise Air Compressor with Air Dryer
- RS-232C Serial Interface

DESCRIPTION

The **Model 2500** Benchtop Humidity Generator is a self contained system capable of producing atmospheres of known humidities using the fundamental, NIST proven, "two-pressure" principle. This system is capable of continuously supplying accurately known humidity values for instrument calibration, evaluation, and verification, as well as for environmental testing.

Simply apply power and the **2500** will power-up ready to generate. Humidity setpoint values are input by the operator from the front panel keypad and are limited only by the range of the **2500** humidity generator.

Relative humidities are calculated from the measurements of pressure and temperature with the formula:

$$\%RH = \frac{f_s}{f_c} \cdot \frac{e_s}{e_c} \cdot \frac{P_c}{P_s} \cdot 100$$

To generate a known humidity, the computer controls the pressure ratio P_c/P_s utilizing the enhancement factor ratio f_s/f_c and the effective degree of saturation e_s/e_c . Humidity produced is solely dependent on the measurement of pressures and temperatures and does not rely on any other device (such as a dew point hygrometer, psychrometer, or humidity sensor) for the measurement of water vapor content. Precision humidity generation is determined by the accuracy of the pressure measurements and on the accuracy and uniformity of temperature throughout the generating system.



PRINCIPLE OF OPERATION

The **Model 2500** Benchtop Humidity Generator operates using an on board multifunction CPU in conjunction with other peripheral cards to perform calculation and control functions. The embedded computer control system allows the **2500** to generate known humidity levels unattended, freeing the operating technician from the task of system monitoring and adjustment. A computer and/or printer may be connected via the bidirectional RS-232C interface ports allowing remote setpoint control and continuous acquisition of system data.

Humidity and temperature setpoint values are input by the operator from the front panel keypad while visual indications of system status are displayed in real time on the liquid crystal display.

	SetPnt	Actual	
%RH @ P _c	50.25		CHNG SETP
%RH @ P _c T _c	50.00		EDIT ICAL
SATUR CHMBR	PSI	29.40	PRNT OFF
SATUR CHMBR	°C	21.10	RUN
FLOW	SLM	20.00	
			EMULIJF

Control Display

All control and measurement parameters critical to the operation of the humidity generator are displayed on this screen. Each parameter in the left most column is identified with a brief title and corresponding units. The generator

operates in a variety of user selectable pressure, temperature, and flow units. Some of these are °C, °F, psi, "Hg, Tor, mbar, kPa, l/m, l/h, cfm and cfh. Humidity is calculated and displayed in percent relative humidity (%RH). The asterisk in the left most column indicates the active humidity control parameter. The "SetPnt" column lists control setpoints and the "Actual" column lists all of the measured data and calculated parameters of the generator.

Temperature Control: The system utilizes a fluid jacketed test chamber for extremely stable temperature control. Temperature setpoint control is attained by controlling the temperature of the circulating fluid medium that jackets the test chamber and associated humidity generation components. Chamber and saturation temperatures are governed by this medium and are digitally controlled by the computer at any value between 0°C and 70°C using PID (proportional-integral-derivative) algorithms.

Pressure And Flow Control: Pressure control and mass flow control are accomplished through computer actuation of electromechanical valve assemblies. Pressure and flow are measured continuously and controlled using PID algorithms similar to those employed in temperature control.

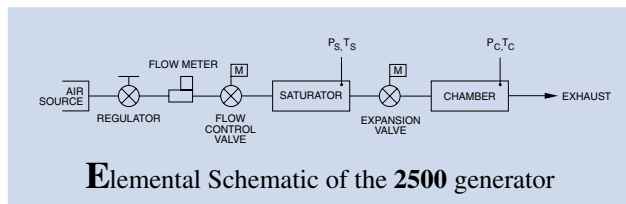

Elemental Schematic of the 2500 generator

Calibration: The 2500 humidity generator employs an integral programmable calibration scheme allowing the temperature and pressure transducers to be calibrated while they are electrically connected to the humidity generator.

	Count	Deg C	LOW TEMP
* Satur Tmp	1180	23.41	MID TEMP
* PrSat Tmp	1165	23.12	HIGH TEMP
* Expan Tmp	1173	23.20	
* Chamb Tmp	1155	23.08	
* Refer Tmp	1257	.1364	
LOW	MID	HIGH	EXIT QUIT
0	35	70	

Calibration Display

Coefficients for each transducer are calculated by the computer and stored in the system's nonvolatile memory until the next calibration is performed.

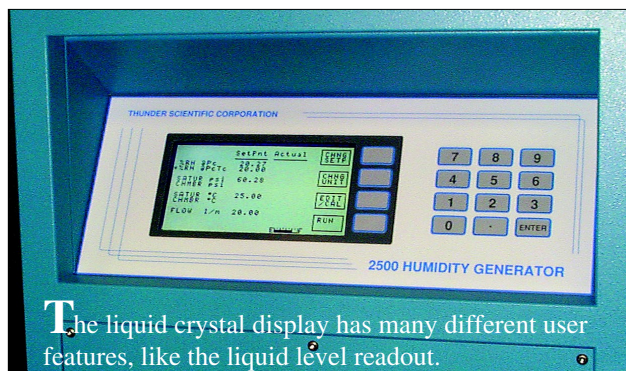

The liquid crystal display has many different user features, like the liquid level readout.

APPLICATIONS

The fluid jacketed test chamber can accommodate humidity sensors, hygrometers, chilled mirror hygrometers, and various material samples for environmental testing.



Virtually any humidity and temperature point may be generated, for any length of time, within the operational limits of the generator. The output of the device under test may then be compared with the generator's printed data for analysis.

Humidity Sensors And Chart Recorders: Insert humidity probes through the two inch port in the side of the chamber or place hygrometers into the chamber and you can: determine humidity calibration accuracy and characterize humidity sensitivity by subjecting the sensing system to a variety of humidity levels; perform operational checks such as the sensing systems capability to correctly calculate and display other humidity parameters; determine the repeatability, stability, hysteresis, and drift characteristics of various humidity sensing systems.

Chilled Mirror Hygrometers: Install the actual chilled mirror head into the chamber or insert a sample tube through the test port and draw a sample through the chilled mirror head and you can: verify mirror temperature measurement accuracy (calibration) when the hygrometer is in thermal equilibrium with its environment; perform operational checks of the heat pump and optical components before and after mirror cleaning and balancing; determine whether the hygrometer is controlling the mirror deposit in the liquid phase or ice phase when operating at dew and frost points below 0°C; determine if the hygrometer is correctly calculating other humidity parameters; determine the hygrometer's repeatability, stability, and drift characteristics.

Environmental Testing: The 2500 can serve as a test bed for evaluation and R&D of humidity sensors, humidity sensing systems, and humidity sensitive products, e.g., polymers, composites, film, magnetic medium, blood gas analysis, pharmaceuticals, soil hydrology, consumables, electronics, optics, etc. Depending on the temperature and humidity being generated, the 2500 may operate continuously from hours to months. With continuous generation of a nominal 50 %RH at 21°C, the reservoir will last about two weeks between refills.

Model 2500 Benchtop / Mobile "Two-Pressure" Humidity Generator

SPECIFICATIONS

Relative Humidity Range: 10 to 98%
 Relative Humidity Resolution: 0.02%
 Relative Humidity Accuracy (k=2) @ P_cT_c: ±0.5%
 Chamber Temperature Range: 0 to 70°C
 Chamber Temperature Range: (Optional) -10 to +70°C
 Chamber Temperature Resolution: 0.02°C
 Chamber Temperature Uniformity: * ±0.1°C
 Chamber Temperature Accuracy: ±0.06°C
 Chamber Pressure Range: Ambient
 Gas Flow Rate Range: 5 to 20 l/m
 Gas Type: Air or Nitrogen
 Gas Pressure Rating (MAWP): 175 psiG
 Heating/Cooling Rate: 2.5 Minutes Per °C Average
 Chamber Window: 6" x 6" (152 mm x 152 mm)
 Physical Dimensions: Table A
 Physical Dimensions With Cart: Table B
 Chamber Dimensions: Table C
 Access Port: Table D

UTILITIES

Electrical Power: 100/120 V~, 15 A, 50/60 Hz
 (Optional) 200/240 V~, 8 A, 50/60 Hz
 Air Compressor: 100/120 V~, 5 A, 50/60 Hz
 (Optional) 200/240 V~, 2.5 A, 50/60 Hz
 Air Supply (External): Clean Oil Free Instrument Air
 @ 175 psiG & 20 slpm

ENVIRONMENTAL

Operating Temperature: 15 to 30°C
 Storage Temperature: 0 to 50°C
 Humidity: 5 to 95% Non-condensing

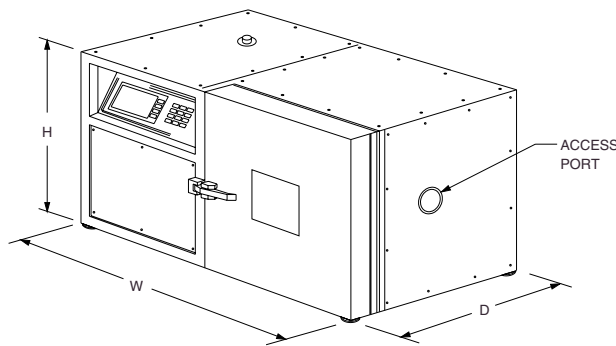

* When operated at temperatures within 10°C of room ambient temperature.

For More Information or to Place an Order Contact:



Thunder Scientific

623 Wyoming S.E. • Albuquerque, New Mexico 87123-3198
 Ordering: 800.872.7728 • Tel: 505.265.8701 • FAX: 505.266.6203

www.thunderscientific.com

032000-2500

TABLE A
Physical Dimensions

Model	H	W	D
2500	19" (483 mm)	33" (838 mm)	20" (508 mm)
2500S		36" (914 mm)	
2500ST	22" (559 mm)		23" (584 mm)

Not including feet, handle, or other protrusions.

TABLE B
Overall Dimensions With Cart

Model	H	W	D
2500	53" (1.35 m)	40" (1.02 m)	23" (584 mm)
2500S		43" (1.09 m)	
2500ST	56" (1.42 m)		26" (660 mm)

TABLE C
Chamber Dimensions

Model	H	W	D
2500	12" (305 mm)	12" (305 mm)	10" (254 mm)
2500S		15" (381 mm)	
2500ST	15" (381 mm)		12" (305 mm)

TABLE D
Access Port Dimensions

Option	# Ports	Port Diameter	Location
Standard	1	1.9" (48 mm)	Right Side
-DPV	1	1.9" (48 mm)	Right Side
	1	1/4" Swagelok	Right Side
-TPA	2	1.9" (48 mm)	Right Side
	1	1/4" Swagelok	Right Side
-MPD	6	1.1" (28 mm)	In Door

Other custom options are available.

